

## SL716-20KHD 7' x 16', 20,000 lb. Tandem Axle Dump Trailer with 3-Way Tailgate



### Standard Features

- Spare Tire Included
- Slide in Ramps
- Stake Pockets
- Scissor hoist – Power Up / Power Down
- Adjustable Coupler
- Roll Up Tarp
- Rear Drop Down Stabilizer Jacks
- Aluminum Pump Box
- 110V Battery Charger
- PPG DTM 2 Part Epoxy Paint

### Specifications

<b>Axle:</b>	(2) 10,000 Lippert Torsion	<b>Floor &amp; Wall:</b>	3/16 Floor / 10ga Wall
<b>Hoist:</b>	Champion CS6-20T 13 Ton	<b>Frame:</b>	Engineered Beam 90 KSI Steel
<b>Jack:</b>	14,000 lb Hydraulic Bolted	<b>Lights:</b>	LED
<b>Ramp:</b>	4,500 lb Mid Span	<b>Electric Plug:</b>	7 Wire RV
<b>Wheels:</b>	235/75R17.5 H Steel	<b>Safety Chains:</b>	26,400 lb
<b>Tailgate:</b>	Steel Three Way Barn/Spreader	<b>Paint Specs:</b>	PPG 2-Part Epoxy DTM
<b>Coupler:</b>	21,000 lb Demco Adjustable		

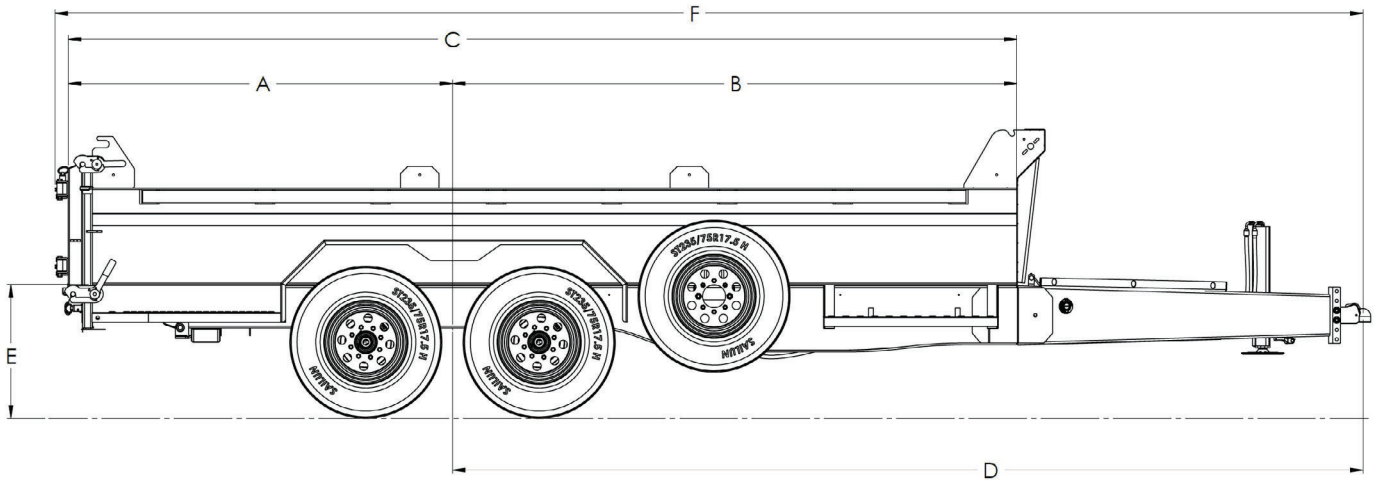

## Dimensions

Model	A	B	C	D	E	F
SL716-20KHD	80"	117"	197"	189"	27 3/4"	272"

Model	Description	Net Weight	GVWR	Payload Cap.
SL716-20KHD	7' x 14' 16,000 lb. Tandem Axle Black/Charcoal	5,700 lb	21,000 lb	15,300 lb



Specs are subject to change without notice. Please contact Southland Trailer Corp Product Specialist for price confirmation on all Products. - Revised January 2024