

# SL714-16KHD 17.5W

## 7' x 14', 16,000 lbs. Heavy Duty Tandem Axle Dump Trailer



### Standard Features

- 168" Inside Box Length
- 26" Wall Height
- 88" Inside Box Width
- 7 GA Floor
- 4,000 lb. Aluminum Slide-In Ramps
- Spare Tire Carrier
- Welded Fenders
- Tarp
- Slam Lock, 3-Way Tailgate
- 8,000 lb. Hydraulic Jack
- Aluminum Toolbox w/ LED Light, Charging System, Removable
- Tray, and Magnetic Remote Holder
- Breakaway Kit
- All Enclosed Wiring
- LED Lighting Package
- Bolt-on Safety chains & Hooks
- Lippert Equa-Flex Axles
- Radial 12 Ply Tires
- Steel Component cleaned with Steel Shot Blast
- Polyurethane Two Component Paint Process

### Specifications

<b>Tailgate:</b>	3-Way Tailgate, Slam Lock	<b>Coupler:</b>	2 5/16"
<b>Lights:</b>	L.E.D. DOT Stop, Tail, Turn, & Clearance	<b>Tires:</b>	215/75R17.5 H
<b>Suspension:</b>	Multi-Leaf Spring w/ Equalizer	<b>Rims:</b>	16 x 6; Steel 8 Bolt
<b>Safety Chains:</b>	16,200 lb. 3/8" x 35" w/Clevis Slip Hook	<b>Brakes:</b>	Electric
<b>Jack:</b>	7,000 lb. Topwind	<b>Frame:</b>	6" x 2" HSS Tube
<b>Hoist:</b>	13 Ton Double Acting Hydraulic Underbody Hoist	<b>Crossmember:</b>	Sill Design
<b>Fenders:</b>	14 GA Checkerplate	<b>Tongue:</b>	6" x 2" HSS Tube
<b>Floor:</b>	10 GA Steel Sheet	<b>Electric Plug:</b>	7 Wire RV Plug
<b>Axle:</b>	(2) 8000 lb. w/ Electric Brakes		

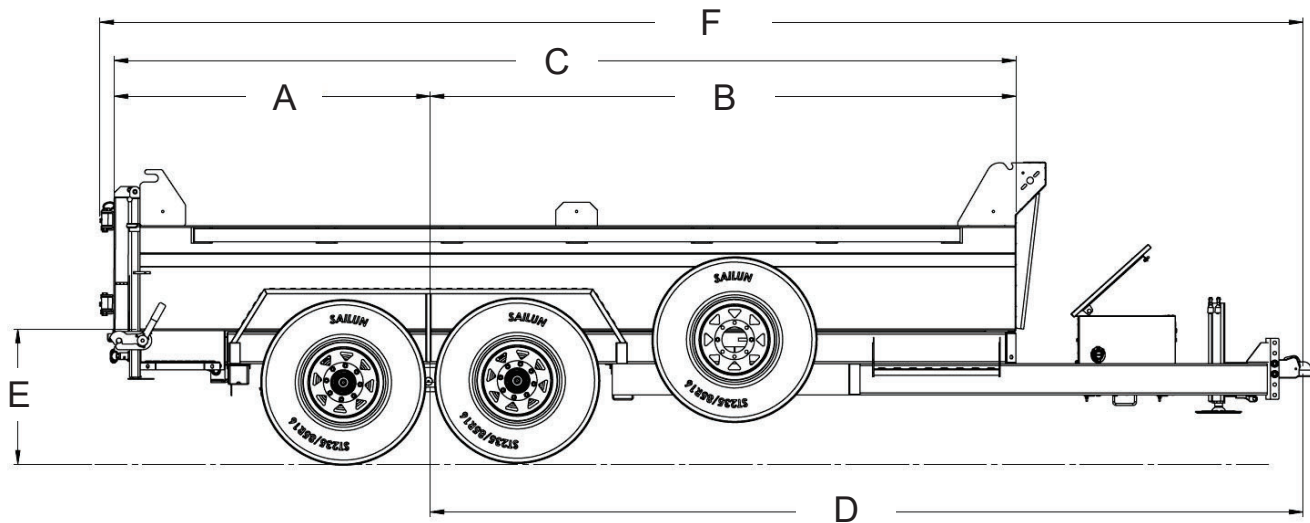

## Dimensions

Model	A	B	C	D	E	F
SL714-16KHD 17.5W	60 11/16"	112 7/16"	173 1/16"	167 1/2"	25 13/16"	230 15/16"

Model	Description	Net Weight	GVWR	Payload Cap.
SL714-16KHD 17.5W	7.5' x 14' 17.5W 16,000 lbs. Tandem Axle Black/Charcoal	3,703 lb.	17,600 lb.	13,897 lb.

## Standard Parts

**Part# 2028** – AXLE 80-865E 93.0" X 79.0" STR EYE TO EYE U/S

**Part# 2440** – LIGHT LICENSE PLATE SURFACE MOUNT MINI CHROME - LED

**Part# 51105** – JCT BOX AND 6FT LEAD PACKAGE

**Part#57637** – LIGHT STOP TURN TAIL RED 6.5" X 2.5" OVAL LED – 10 DIODE

**Part# 1879** – BREAKAWAY SWITCH C/W PULL PIN

**Part#87997** – TOOLBOX ALUMINUM TRAILER TONGUE STYLE W/ GAS SHOCK

**Part# 843** – COUPLER CHANNEL MOUNT 22,000 lb. 2.3125" - W/ 6 HOLE CHANNEL & HARDWARE

**Part#76835REV1** – 4,000 lb. RAMP ALUMINUM 6FT CHANNEL SLIDE UNDER

**Part# 77748** – FENDER TANDEM STEEL 75.875" X 9" X 10" - 14 GA CHECKERPLATE

**Part#51126** – HYDRAULIC POWER UNIT 12V ELECTRIC DUAL DOUBLE ACTING

**Part# 4375** – SL280 HYD JACK PACKAGE

**Part# 71384** – TARP 6.5' X 18.0' C/W HARDWARE KIT

**Part# 1329** – LIGHT CLEARANCE AMBER 0.6875" ROUND LED W/ GROMMET

**Part# 55961** – TIRE ASSEMBLY 235/85R16 F 12 PLY 8 HOLE BLACK (5/8" STUDS) #3960

**Part#1332** – LIGHT CLEARANCE RED 0.6875" ROUND LED W/ GROMMET



Specs are subject to change without notice. Please contact Southland Trailer Corp Product Specialist for price confirmation on all Products. - Revised August 2023