



## Standard Features

- 10' Box Length
- 5' Box Width
- 8' Overall Width
- 12 GA Floor
- 2,500 lb. Low Profile Steel Ramps
- Spare Tire Carrier
- Welded Fenders
- Stake Pockets & Rub Rails
- Tarp
- Slam Lock, Double Door Tailgate
- Rear Drop Down Stabilizer Jacks
- Aluminum Tool Box
- Breakaway Kit
- Protected Wiring
- LED Lighting Package
- Fully Enclosed Wiring
- Bolt-on Safety chains & Hooks
- Lippert Brand Axles
- Radial 6 Ply Tires
- Steel Component cleaned with Steel Shot Blast
- Polyurethane Two Component Paint Process

## Specifications

<b>Tailgate:</b>	Double Door Tailgate/Slam Lock	<b>Coupler:</b>	2 5/16"
<b>Lights:</b>	L.E.D. DOT Stop, Tail, Turn, & Clearance	<b>Tires:</b>	ST205/75R 15 C
<b>Suspension:</b>	Multi-Leaf Sprng w/ Equalizer	<b>Rims:</b>	15 x 6; Steel 5 Bolt
<b>Safety Chains:</b>	16,200 lb. 3/8" x 35" w/Clevis Slip Hook	<b>Brakes:</b>	Electric
<b>Jack:</b>	5,000 lb. Sidewind	<b>Frame:</b>	4" x 2" HSS Tube
<b>Hoist:</b>	7 Ton Double Acting Hydraulic Underbody Hoist	<b>Crossmember:</b>	N/A
<b>Fenders:</b>	46.75" x 9.9375" x 8.8125", 14 GA Checkerplate	<b>Tongue:</b>	4" x 2" HSS Tube
<b>Floor:</b>	12 GA Steel Sheet	<b>Electric Plug:</b>	7 Wire RV Plug
<b>Axle:</b>	(2) 3,500 lb. w/ Electric Brakes		

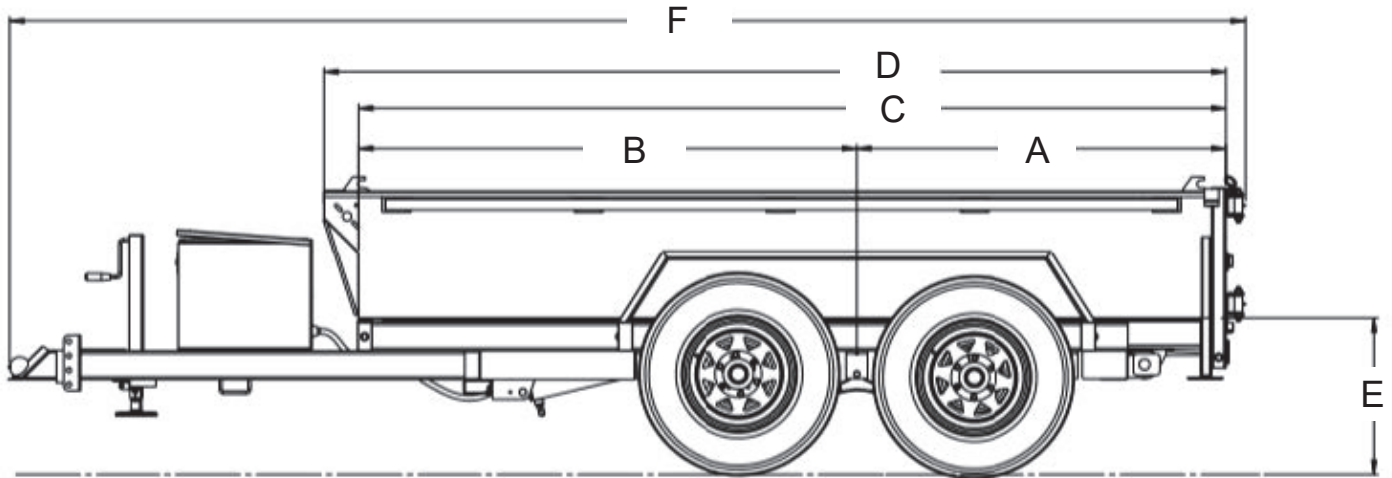

## Dimensions

Model	A	B	C	D	E	F
SL510-7K	51 5/8"	69 7/8"	121 1/2" x 61 1/2"	126 5/16"	21 13/16"	21 13/16"

Model	Description	Net Weight	GVWR	Payload Cap.
SL510-7K	5' x 10' 7,000 lb. Tandem Axle Black/Charcoal	2,193 lb.	2,193 lb.	5,507 lb.

## Standard Parts

**Part# 51581** – AXLE 35-545E 73.0" X 59.0" STR EYE-to-EYE U/S

**Part# 2440** – LIGHT LICENSE PLATE SURFACE MOUNT MINI CHROME - LED

**Part# 51105** – JUNCTION BOX AND 6FT LEAD PACKAGE

**Part# 57637** – LIGHT STOP TURN TAIL RED 6.5" X 2.25" OVAL LED - 10 DIODE

**Part# 1879** – BREAKAWAY SWITCH C/W PULL PIN

**Part# 87997** – TOOLBOX ALUMINUM TRAILER TONGUE STYLE W/ GAS SHOCK

**Part# 63021** – COUPLER CHANNEL MOUNT 14,000 lb. 2.3125" - W/ 4 HOLE CHANNEL & HARDWARE

**Part# 94676** – 2,500 lb. LOW PROFILE ECONO RAMP

**Part# 94493** – JEEP FENDER SINGLE - 8.5" WIDE

**Part# 51120** – HYDRAULIC POWER UNIT 12V ELECTRIC DOUBLE ACTING

**Part# 2281** – JACK SIDEWIND 5,000 lb. WELD-ON 15.0" LIFT DROP LEG SQUARE

**Part# 94495** – TARP 5.0' X 10.0' C/W HARDWARE KIT

**Part# 1329** – LIGHT CLEARANCE AMBER 0.6875" ROUND LED W/ GROMMET

**Part# 82027** – TIRE ASSEMBLY 205/75R15 C 6 PLY 5 ON 4.5" BLACK MOD

**Part# 1332** – LIGHT CLEARANCE RED 0.6875" ROUND LED W/ GROMMET



Specs are subject to change without notice. Please contact Southland Trailer Corp Product Specialist for price confirmation on all Products. - Revised October 2023