



### Standard Features

- NEW Tarp Hooks
- NEW Gate Holdback Including HSS Spring Enclosure And Galvanized Steel Strike Plates
- Stake Pockets
- Scissor Hoist – Power Up / Power Down
- Adjustable Coupler
- Aluminum Toolbox
- 110V Battery Charger
- 10W Solar Panel
- PPG DTM 2 Part Epoxy Paint
- Fully Enclosed Wiring
- Redesigned Rear Step
- HSS Structural Tubing
- Engineered Sill Design
- Spare Tire\*
- Galvanized Steel Slide in Ramps\*
- Roll Up Tarp\*
- Rear Drop Down Stabilizer Jacks\*
- 8" Side Boards\*

\*Dealer Specific Options

### Specifications

<b>Axle:</b>	(1) 5,200 lb. Lippert Spring	<b>Floor &amp; Wall:</b>	12ga Floor / 14ga Wall
<b>Hoist:</b>	Champion CS412T 5 Ton	<b>Frame:</b>	4 X 2 HSS
<b>Jack:</b>	7,000 lb, Bolted, Top wind, Pull Pin Drop Leg	<b>Lights:</b>	LED
<b>Ramp:</b>	(2) 2,500 lb. Midspan Ramps (47 lbs. each)	<b>Electric Plug:</b>	Cold Weather 7 Wire RV
<b>Wheels:</b>	225/75R15 D Steel	<b>Safety Chains:</b>	16,200 lb 5/16"
<b>Tailgate:</b>	Steel Barn Door	<b>Paint Specs:</b>	PPG 2-Part Epoxy DTM
<b>Coupler:</b>	21,000 lb. Demco Adjustable	<b>Dump Angle:</b>	45°

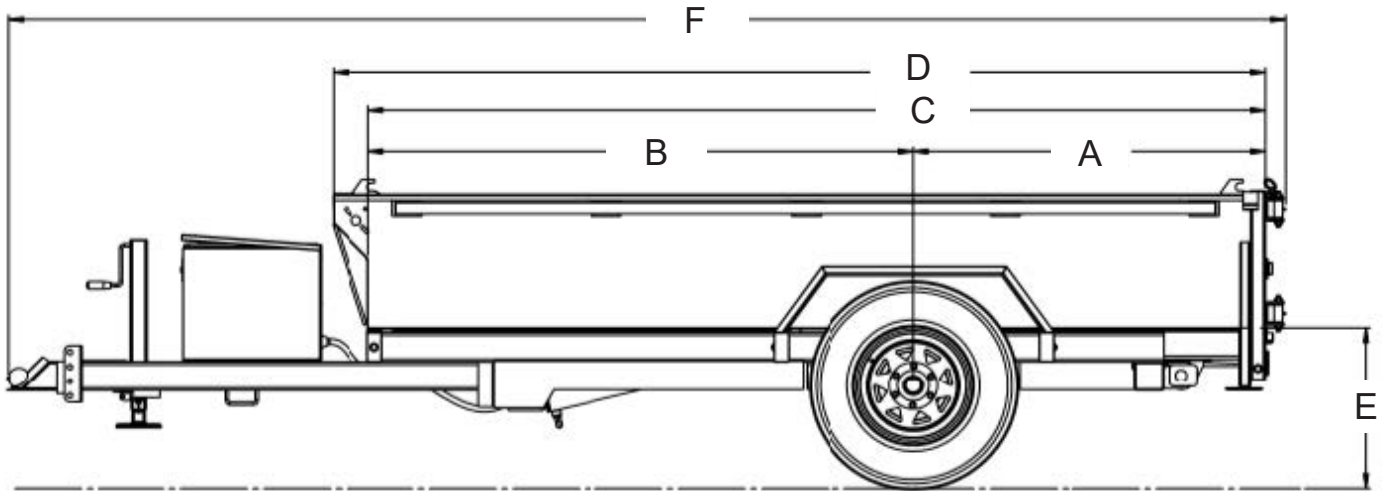

## Dimensions

Model	A	B	C	D	E	F	Box Width
SL510-5K	47 1/2"	74"	121 1/2"	126 1/4"	21 3/4"	173"	62"

Model	Description	Net Weight	GVWR	Payload Cap.
SL510-5K	5' x 10' 5,000 lb. Single Axle Black/Charcoal	1,979 lb.	5,720 lb.	3,741 lb.



Specs are subject to change without notice. Please contact Southland Trailers Product Specialist for price confirmation on all Products. - Revised February 2026