



Standard Features

- Stake Pockets
- Scissor Hoist – Power Up / Power Down
- Adjustable Coupler
- Aluminum Toolbox
- 110V Battery Charger
- 10W Solar Panel
- PPG DTM 2 Part Epoxy Paint
- Fully Enclosed Wiring
- HSS Structural Tubing
- Engineered Sill Design
- Spare Tire*
- Galvanized Steel Slide in Ramps*
- Roll Up Tarp*
- Rear Drop Down Stabilizer Jacks*
- Side Boards*

*Dealer Specific Options

Specifications

Axle:	(1) 5,200 lb. Lippert Spring	Floor & Wall:	12ga Floor / 14ga Wall
Hoist:	Champion CS412T 5 Ton	Frame:	4 X 2 HSS
Jack:	7,000 lb. Top-Wind Bolted	Lights:	LED
Ramp:	(2) 2,500 lb. Midspan Ramps (47 lbs. each)	Electric Plug:	7 Wire RV
Wheels:	225/75R15 D Steel	Safety Chains:	16,200 lb.
Tailgate:	Steel Barn Door	Paint Specs:	PPG 2-Part Epoxy DTM
Coupler:	21,000 lb. Demco Adjustable	Dump Angle:	45°

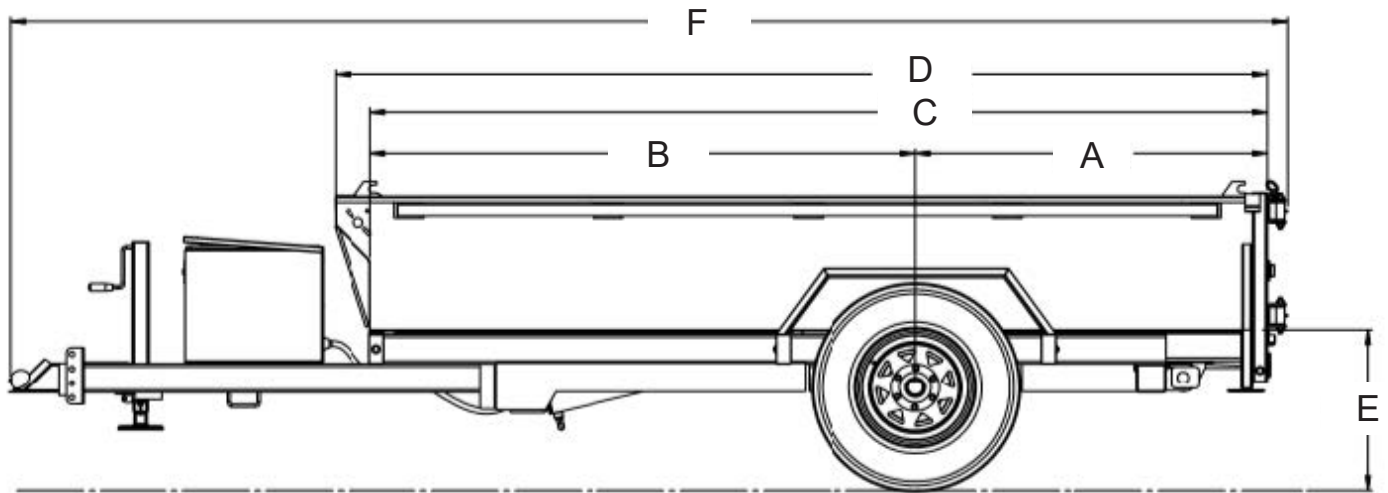

Dimensions

Model	A	B	C	D	E	F	Box Width
SL510-5K	47 1/2"	74"	121 1/2"	126 1/4"	21 3/4"	173"	62"

Model	Description	Net Weight	GVWR	Payload Cap.
SL510-5K	5' x 10' 5,000 lb. Single Axle Black/Charcoal	2,101 lb.	5,720 lb.	3,619 lb.



Specs are subject to change without notice. Please contact Southland Trailers Product Specialist for price confirmation on all Products. - Revised June 2025