

## SL610-7K 6' x 10', 7,000 lb. Tandem Axle Dump Trailer



### Standard Features

- Spare Tire Included
- Slide in Ramps
- Stake Pockets
- Scissor hoist – Power Up / Power Down
- Adjustable Coupler
- Roll Up Tarp
- Rear Drop Down Stabilizer Jacks
- Aluminum Pump Box
- 110V Battery Charger
- PPG DTM 2 Part Epoxy Paint

### Specifications

<b>Axle:</b>	(2) 3,500 lb Lippert Spring	<b>Floor &amp; Wall</b>	12ga Floor / 14ga Wall
<b>Hoist:</b>	Champion CS412T 5 Ton	<b>Frame:</b>	6 X 2 X 0.148 HSS
<b>Jack:</b>	7,000 lb Top-Wind Bolted	<b>Lights:</b>	LED
<b>Ramp:</b>	2,500 lb Mid-Span	<b>Electric Plug:</b>	7 Wire RV
<b>Wheels:</b>	205/75R15 D Steel	<b>Safety Chains:</b>	16,200 lb
<b>Tailgate:</b>	205/75R15 D Steel	<b>Paint Specs</b>	PPG 2-Part Epoxy DTM
<b>Coupler:</b>	21,000 lb Demco Adjustable		

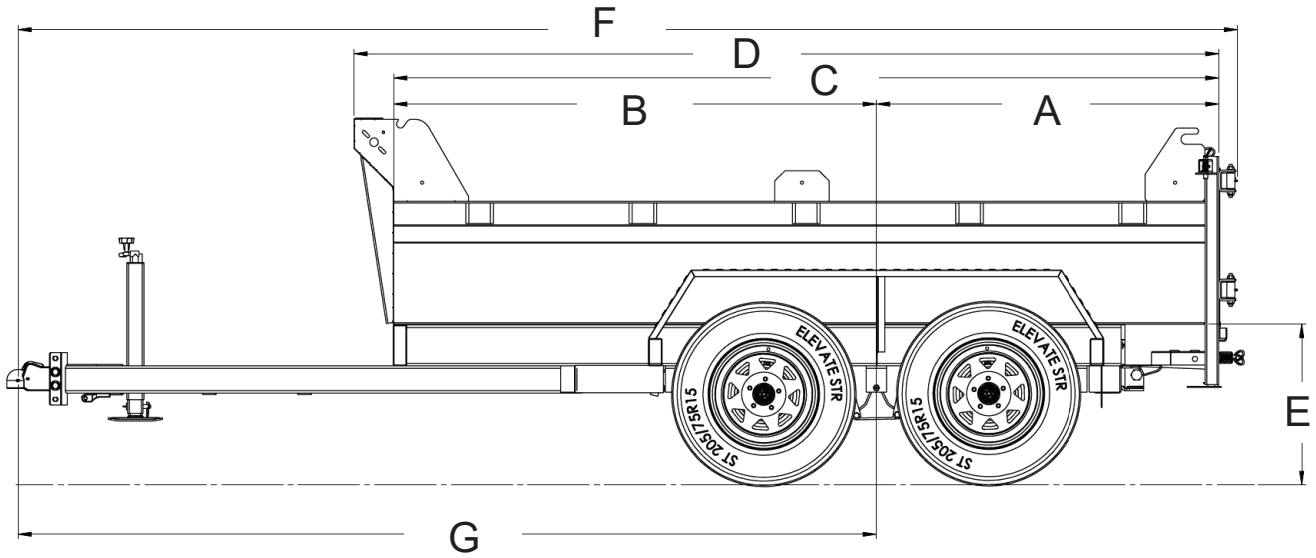

## Dimensions

Model	A	B	C	D	E	F	G
SL610-7K	50 1/4"	71"	121 3/4"	127"	24"	179 1/4"	126 1/8"

Model	Description	Net Weight	GVWR	Payload Cap.
SL610-7K	6' x 10' 7,000 lb. Tandem Axle Black/Charcoal	2,740 lb	7,700 lb	4,960 lb



Specs are subject to change without notice. Please contact Southland Trailer Corp Product Specialist for price confirmation on all Products. - Revised January 2024