



Standard Features

- NEW Tarp Hooks
- NEW Gate Holdback Including HSS Spring Enclosure And Galvanized Steel Strike Plates
- Stake Pockets
- Scissor Hoist – Power Up / Power Down
- Adjustable Coupler
- Aluminum Toolbox
- 110V Battery Charger
- 10W Solar Panel
- PPG DTM 2 Part Epoxy Paint
- Fully Enclosed Wiring
- Redesigned Rear Step
- HSS Structural Tubing
- Engineered Sill Design
- Spare Tire*
- Galvanized Steel Slide in Ramps*
- Roll Up Tarp*
- Rear Drop Down Stabilizer Jacks*
- 8" Side Boards*

*Dealer Specific Options

Specifications

Axle:	(2) 5,200 lb. Lippert Spring	Floor & Wall:	12ga Floor / 14ga Wall
Hoist:	Champion CS412T 5 Ton	Frame:	4 X 2 HSS
Jack:	7,000 lb, Bolted, Top wind, Pull Pin Drop Leg	Lights:	LED
Ramp:	(2) 2,500 lb. Midspan Ramps (47 lbs. each)	Electric Plug:	Cold Weather 7 Wire RV
Wheels:	225/75R15 D Steel	Safety Chains:	16,200 lb 5/16"
Tailgate:	Steel Barn Door	Paint Specs:	PPG 2-Part Epoxy DTM
Coupler:	21,000 lb. Demco Adjustable	Dump Angle:	45°

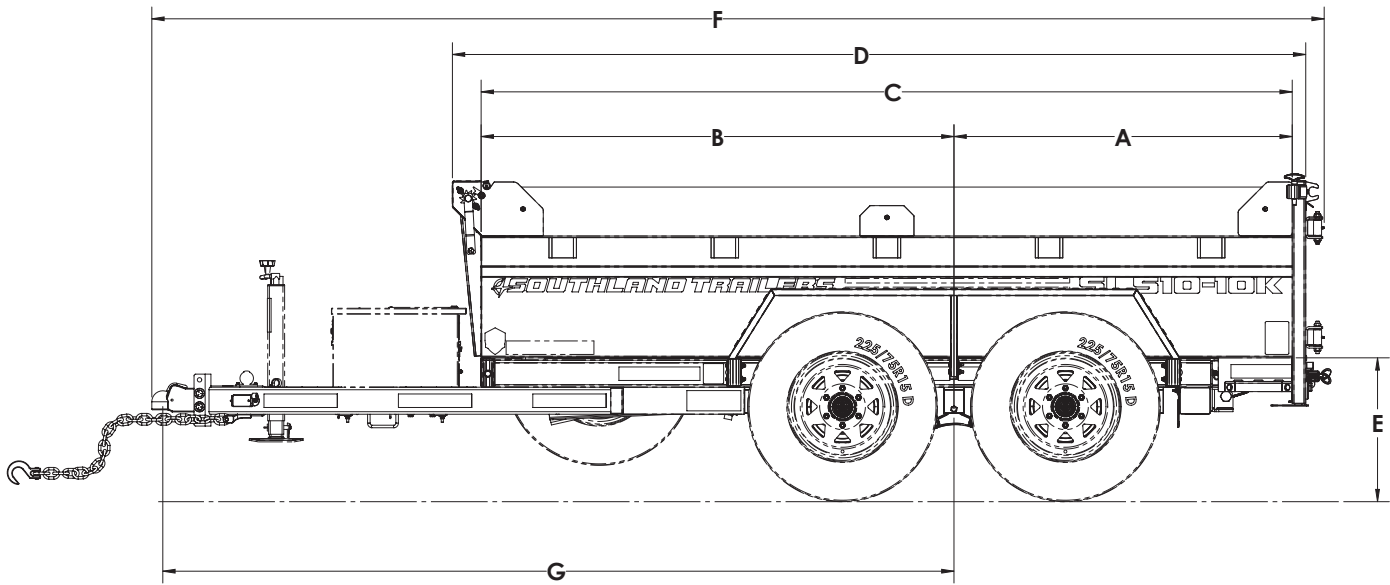

Dimensions

Model	A	B	C	D	E	F	Box Width
SL510-10K	51 1/2"	70"	121 1/2"	126 1/4"	21 3/4"	173"	62"

Model	Description	Net Weight	GVWR	Payload Cap.
SL510-10K	5' x 10' 10,000 lb. Tandem Axle Black/Charcoal	2,239 lb.	11,400 lb.	9,201 lb.



Specs are subject to change without notice. Please contact Southland Trailers Product Specialist for price confirmation on all Products. - Revised February 2026