

SL714-16KHD 7' x 14', 16,000 lb. Heavy Duty Tandem Axle Dump Trailer



Standard Features

- Spare Tire Included
- Slide in Ramps
- Stake Pockets
- Scissor hoist – Power Up / Power Down
- Adjustable Coupler
- Roll Up Tarp
- Rear Drop Down Stabilizer Jacks
- Aluminum Pump Box
- 110V Battery Charger
- PPG DTM 2 Part Epoxy Paint

Specifications

Axle:	(2) 8,000 lb Lippert Spring	Floor & Wall	3/16 Floor / 10ga Wall
Hoist:	Champion CS615T 9 Ton	Frame:	6 X 2 X 0.188 HSS
Jack:	8,000 lb Hydraulic Bolted	Lights:	LED
Ramp:	4,500 lb Mid Span	Electric Plug:	7 Wire RV
Wheels:	235/85R16 G Steel	Safety Chains:	16,200 lb
Tailgate:	Steel Three Way Barn/Spreader	Paint Specs	PPG 2-Part Epoxy DTM
Coupler:	21,000 lb Demco Adjustable		

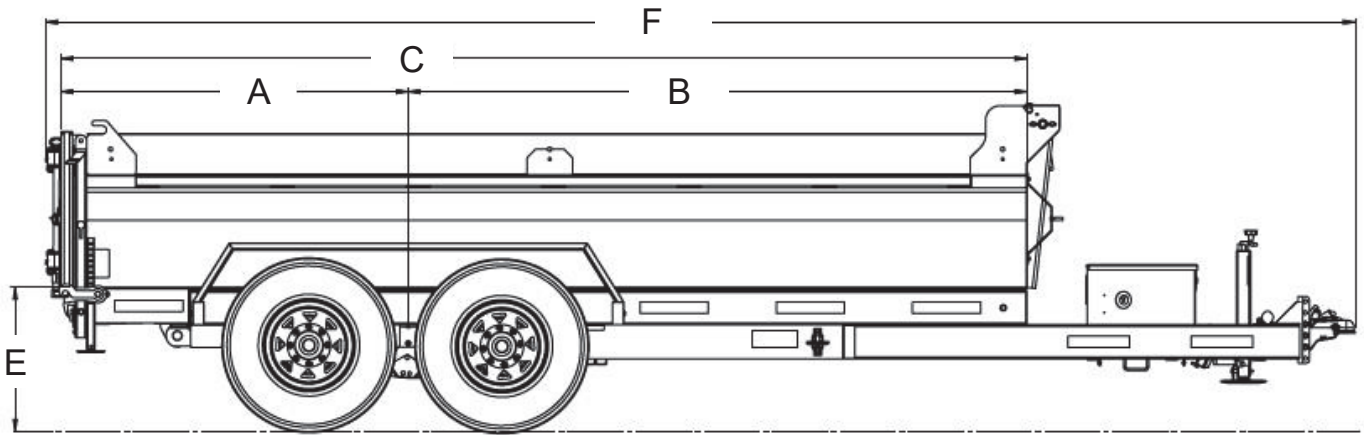

Dimensions

Model	A	B	C	D	E	F
SL714-16KHD	60 3/4"	109 1/4"	170"	176"	25 1/2"	228"

Model	Description	Net Weight	GVWR	Payload Cap.
SL714-16KHD	7' x 14' 16,000 lb. Tandem Axle Black/Charcoal	3,785 lb	17,560 lb	13,775 lb



Specs are subject to change without notice. Please contact Southland Trailer Corp Product Specialist for price confirmation on all Products. - Revised January 2024