



Standard Features

- Stake Pockets
- Scissor Hoist – Power Up / Power Down
- Adjustable Coupler
- Aluminum Toolbox
- 110V Battery Charger
- 10W Solar Panel
- PPG DTM 2 Part Epoxy Paint
- Fully Enclosed Wiring
- HSS Structural Tubing
- Engineered Sill Design
- Spare Tire*
- Aluminum Slide in Ramps*
- Roll Up Tarp*
- Rear Drop Down Stabilizer Jacks*
- Side Boards*

*Dealer Specific Options

Specifications

Axle:	(2) 8,000 lb. Lippert Spring	Floor & Wall:	10ga Floor / 10ga Wall
Hoist:	Champion CS615T 9 Ton	Frame:	6 X 2 HSS
Jack:	12,000 lb. Side Wind Jack Bolted	Lights:	LED
Ramp:	(2) 4,500 lb. Midspan Ramps (33 lbs. each)	Electric Plug:	Cold Weather 7 Wire RV
Wheels:	235/85R16 F Steel	Safety Chains:	16,200 lb 5/16"
Tailgate:	Steel 3-Way Barn/Spreader	Paint Specs:	PPG 2-Part Epoxy DTM
Coupler:	21,000 lb. Demco Adjustable	Dump Angle:	45°

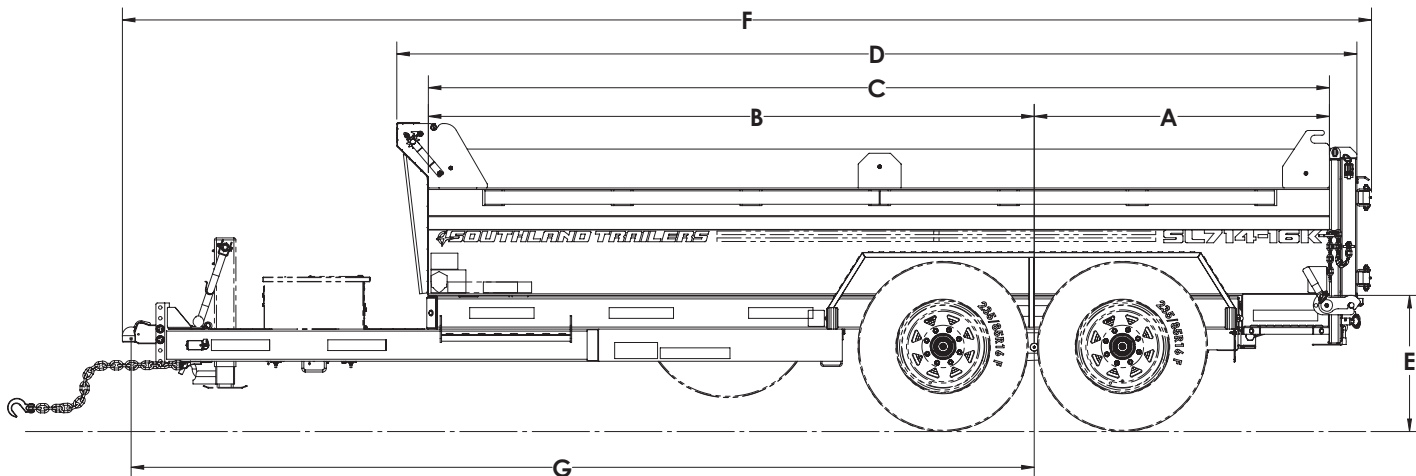

Dimensions

Model	A	B	C	D	E	F	Box Width
SL714-16K	60 3/4"	109 1/4"	170"	176"	25 1/4"	228"	82"

Model	Description	Net Weight	GVWR	Payload Cap.
SL714-16K	7' x 14' 16,000 lb. Tandem Axle Black/Charcoal	4,121 lb.	17,420 lb.	13,299 lb.



Specs are subject to change without notice. Please contact Southland Trailers Product Specialist for price confirmation on all Products. - Revised March 2026