



SLSB-32/28

32' LEAD & 28' REAR SUPER B



General Specifications

Main Beams:	One-Piece Seamless Web 3/16"GR90 KSI HTS, Flange GR130 KSI 5" x 3/8" HTS, Robotically Welded. 2.5" Camber
Main Deck Frame:	3.5" Square Tubing Side Rails w/ Integrated Stake Pockets at 48" Centers, 4" Superlite IBeam Crossmembers on 16" Centers, Fully Welded 1/4" Round Rub Rail, Tube Style Knee Braces, Formed Front Bolster with Bolted Aluminum Inspection Plate, 3.5" Square Tubing Rear Bolster
Coupler Assembly:	3/8" Plate Reinforced with Support Channels and Inner Web Repads, SAF Holland King Pin with Depth Set at 30/19", Various Pin Depth and Plate Thickness Options Available
Cargo Securement:	3 Bar Winches w/Opposite J-Hooks, HD Tarp Hooks. Custom Winch and Stake Pocket Layout Options Available
Decking:	8" x 1-5/16 BC Douglas FIR Shiplap, Exterior Wood Stained for Longevity
Suspension:	Hendrickson AAL23K INTRAAX Air Ride 8" Ride Height. Options Available
Axles:	Hendrickson AANT23K INTRAAX, Lift Axle and Tire Inflation Options Available
Wheelends/Brakes:	Standard 10 Stud Piloted Ductile Iron Hub, Extended Life HXL5, Haldex Auto Slack Adjusters, HXS TSE 30/30 Spring Brake Pots. Cast Drum, Federal Mogul Seals. Disc Brake, Hubmeter and Lightweight Hub and Drum Options Available.
ABS:	Bendix TABS-6 ABS (2 Sensors/1 Modulator), Transport Canada Compliant
Coating:	All Components Steel Shot Blasted, PPG Zinc Rich Epoxy Primer Inside and Out, Top Coat PPG Urethane, All Painted Parts Baked in Heat Ovens, Standard Black. Various Colors Available.
Wiring/Lighting:	HD Sealed Grote Wiring Harness with LED lighting, Wide Load Pull Out and Rear Rear Strobe Lights Options Available.
Air System:	Standard Steel Air tanks, Inline Air Filter System, Manual Air Bag Dump Valve

Landing Gear:	62,500 lb Dual Speed SAF Holland Mark V with Sand Shoe, Heavy Duty Bracing
Tires:	Cooper Roadmaster. Options Available
Rims:	Steel and Aluminum, Various Finish Options Available
Toolbox/Storage:	Aluminum Box with Barn Doors 24"H x 23"D x 60L with Cam Style Latch and Grote LED Interior Light. Various Dunnage Box, Rack and Basket Options Available. Optional Chain Hanger
Mudflaps:	30" Poly Anti-Spray Renn Logo'd Mudflaps. Options Available
Tow Point:	D-Rings Mounted at Rear, Pup Only
Lift Lugs:	Balanced Lift Points on Rear Deck for Stacking Purposes
Reflective Conspicuity:	2" Red and White
Document Holder:	Tube Style
Control Box:	Sealed Aluminum Box with Sight Window, Liquid Load Gauge and Manual Air Bag Dump Valve
Bumper:	Certified Rear Impact Guard, Meets CMVSS
Data:	Meets or Exceeds all Canadian Motor Vehicle Safety Standards

Trailer Ratings

GVWR	Distributed	20' Concentrated	10' Concentrated	4' Concentrated	Tare
41,000/31,500 KG	60,000/60,000 lb.	45,000/45,000 lb	37,500/37,500 lb.	30,000/30,000 lb.	11,400/8,400 lb.

Dimensions

Model	Deck Length	Outside Width	Rear Loaded Deck Height	King Pin Plate Height
SLSB-32/28	32'/28'	102"	L54 15/16"/R49 7/8"	L48 5/8" R47 3/16

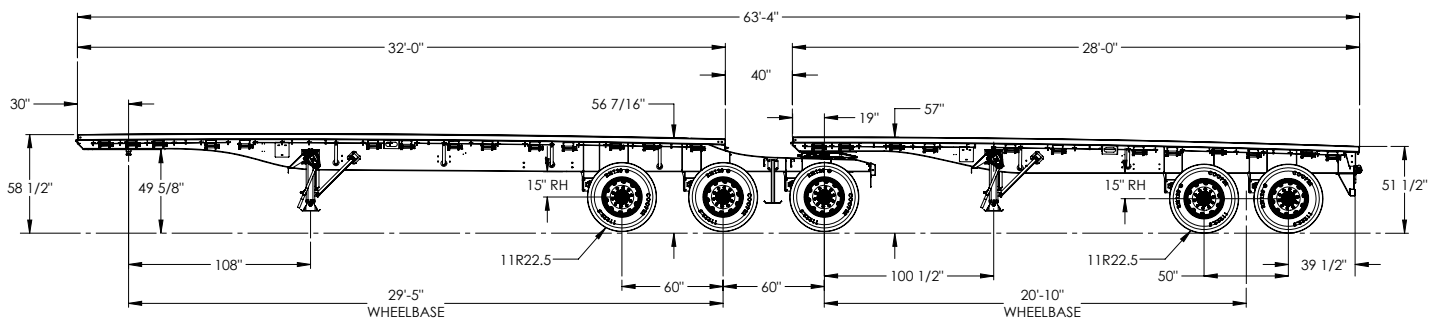

Specs are subject to change without notice. Please contact Southland Trailer Corp Product Specialist for price confirmation on all Products. - Revised January 2025