



SLDD-53

53' DROP DECK



General Specifications

Main Beams:	One-Piece Seamless Web 3/16"GR90 KSI HTS, Robotically Welded Flange GR130 KSI 5" x 3/8" & 1/2" Under the Neck HTS, 2.5" Camber
Main Deck Frame:	6 3/16"Formed SideRails, 4" Superlite IBeam Crossmembers on 12" Centers on Main Deck, 16" on Top Deck, 2-1/2"x 3/8" Continuous Rub Rail, Stake Pockets @ 24" Centers, Tube Style Knee Braces, Formed Front Bolster with 4 Integrated Stake Pockets and Bolted Aluminum Inspection Plate, Formed Rear Bolster with 5 Integrated Stake Pockets
Coupler Assembly:	3/8" Plate Reinforced with Support Channels and Inner Web Repads, SAF Holland King Pin with Depth Set at 18", Various Pin Depth and Plate Thickness Options Available
Cargo Securement:	Stake Pockets @ 24" Centers, 3 Bar Winches w/Opposite J-Hooks, Pipe Spools Between Stake Pockets, HD Tarp Hooks. Custom Winch, Pipe Spool and Stake Pocket Layouts Available
Decking:	8" x 1-5/16 BC Douglas FIR Shiplap, Exterior Wood Stained for Longevity
Suspension:	Hendrickson AAL23K INTRAAX Air Ride 8" Ride Height. Options Available
Axles:	Hendrickson AAL23K INTRAAX, Lift Axle and Tire Inflation Options Available
Wheelends/Brakes:	Standard 10 Stud Piloted Ductile Iron Hub, Extended Life HXL5, Haldex Auto Slack Adjusters, HXS TSE 30/30 Spring Brake Pots. Cast Drum, Federal Mogul Seals. Disc Brake, Hubmeter and Lightweight Hub and Drum Options Available.
ABS:	Bendix TABS-6 ABS (2 Sensors/1 Modulator), Transport Canada Compliant
Coating:	All Components Steel Shot Blasted, PPG Zinc Rich Epoxy Primer Inside and Out, Top Coat PPG Urethane, All Painted Parts Baked in Heat Ovens, Standard Black. Various Colors Available.
Wiring/Lighting:	HD Sealed Grote Wiring Harness with LED lighting, Wide Load Pull Out and Rear Rear Strobe Lights Options Available.
Air System:	Standard Steel Air tanks, Inline Air Filter System, Manual Air Bag Dump Valve

Landing Gear:	62,500 lb Dual Speed SAF Holland Mark V with Sand Shoe
Tires:	Cooper Roadmaster. Options Available
Rims:	Steel and Aluminum, Various Finish Options Available
Toolbox/Storage:	Aluminum Box with Barn Doors 18"H x 23"D x 56.5"L with Cam Style Latch and Grote LED Interior Light. Various Dunnage Box, Rack and Basket Options Available. Optional Chain Hanger
Mudflaps:	30" Poly Anti-Spray Renn Logo'd Mudflaps. Options Available
Tow Point:	Plate with Hole, Mounted at Rear
Dock Bumper:	2 – Mounted at Rear
Reflective Conspicuity:	2" Red and White
Document Holder:	Tube Style
Control Box:	Sealed Aluminum Box with Sight Window, Liquid Load Gauge and Manual Air Bag Dump Valve
Bumper:	Certified Rear Impact Guard, Meets CMVSS
Data:	Meets or Exceeds all Canadian Motor Vehicle Safety Standards

Trailer Ratings

GVWR	Distributed	20' Concentrated	10' Concentrated	4' Concentrated	Tare
84,877 lb.	70,000 lb.	60,000 lb	51,000 lb.	45,000 lb.	14,200 lb.

Dimensions

Model	Deck Length	Outside Width	Top Deck	Bottom Deck	Rear Loaded Deck Height	King Pin Plate Height
SLDD-53	53'	102"	11'	42'	41"	49.5"

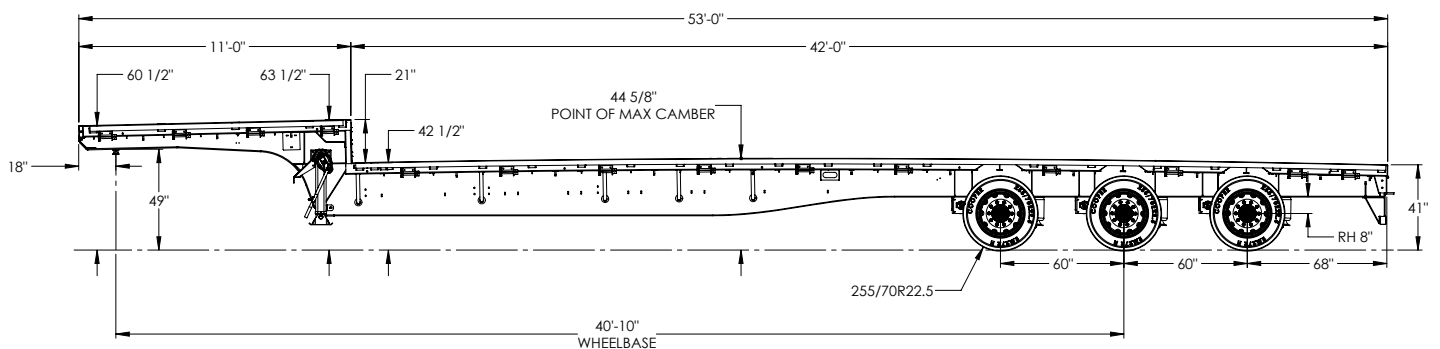

Specs are subject to change without notice. Please contact Southland Trailer Corp Product Specialist for price confirmation on all Products. - Revised May 2024